

ROBO-TEK



Robot Vacuum Cleaner User Manual

Thank you for choosing our robot vacuum cleaner.

Welcome to the Robo-Tek Family

Thanks for using our robot vacuum cleaner.

The Viper is a smart robot vacuum cleaner that can plan its own path. It relies on high-precision laser ranging sensors to build a room map in real time and clean it intelligently and efficiently. With a full-featured base station, it can collect garbage and clean mops automatically. Through the mobile phone APP, you can remotely control the robot in real time.

The Viper is an essential product for you and your family to get rid of tedious floor cleaning housework, and return quality time to you and your family.

Product List



Main Body

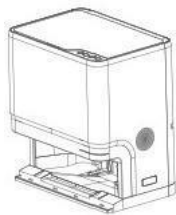

Base Station

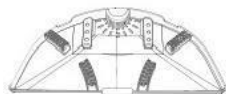

Removable Wash Tray

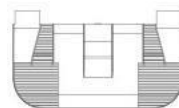

Base Station ramp



Dust Bag



Side brush



Cleaning Tool

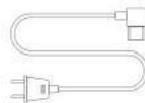

Power Cord

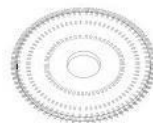

Mop

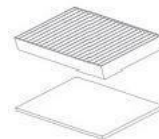

HEPA Filter

Product Introduction

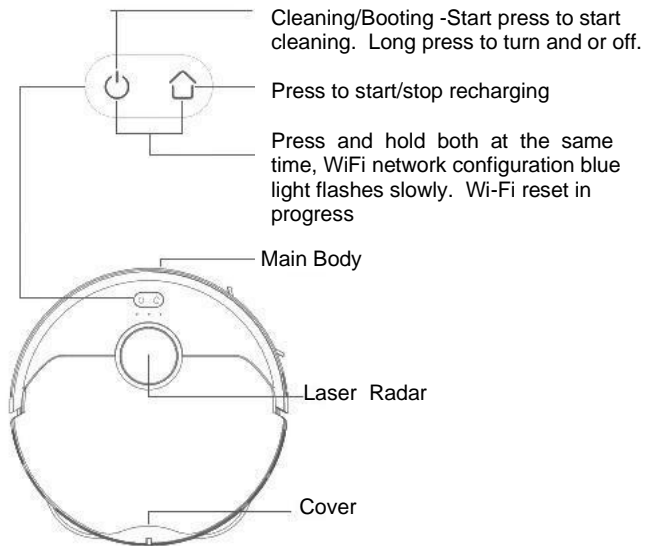

State	Starting light	Recharging light
Network configuration	blue light flashed slowly	blue light flashed slowly
Booting	blue light breathing	blue light breathing
Standby	blue light always on	blue light always on
Fault	red light flashing	red light flashing
Docking	Light of	blue light always on
Charging	Light off	blue light flashed slowly
Fully charged	blue light always on	blue light always on
Updating	blue light flashing	light of
Turning off	Light off	Light off
Sleep	light off	light off

Note: Press any key to stop during cleaning or docking

Product Introduction

Main Body

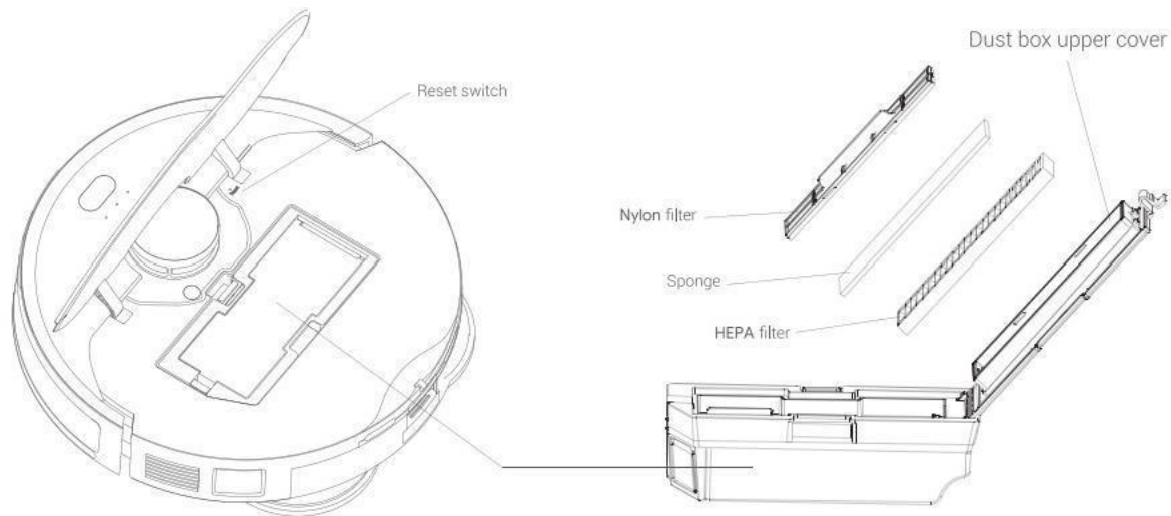

Product Introduction

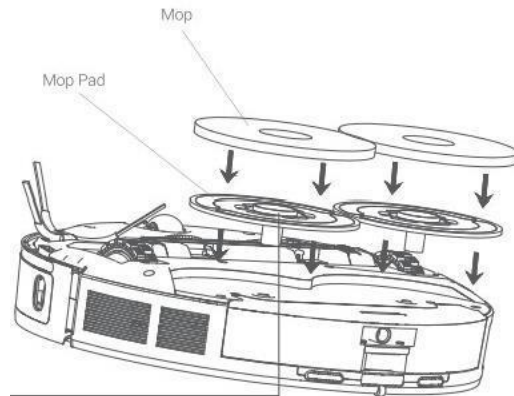
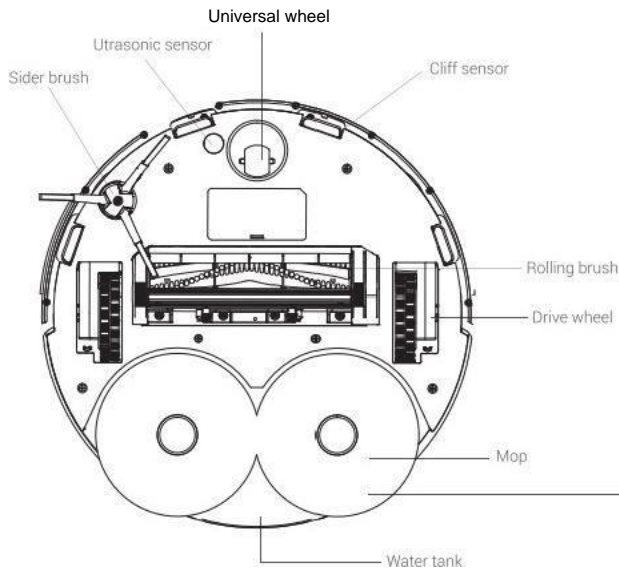

Product Introduction

All-in-One Station

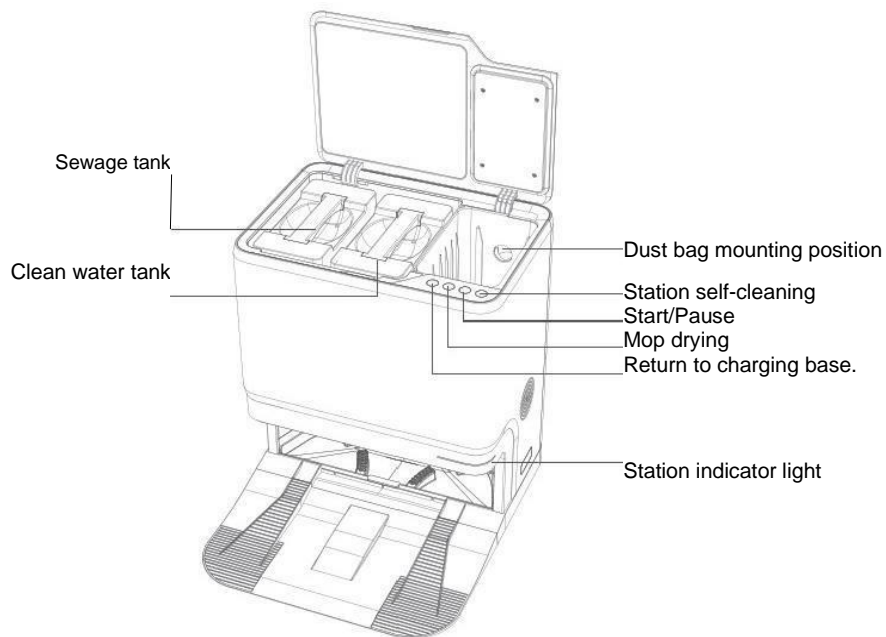

Quick Installation and Use

Installation

1. Install the Station board from the front side up to the slots on both sides of the station. When you hear a click, it is installed correctly, and then press in other positions slightly to ensure the base plate is completely attached to the ground.

Then put the removable wash tray to the inner base.

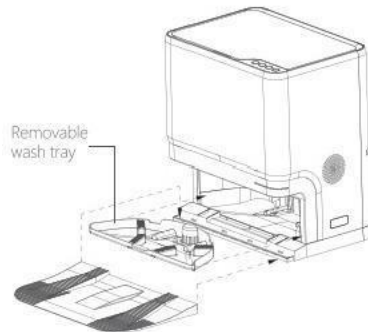

2. Place the base station against a wall on a flat floor. Make sure there is at least 1.6ft/0.5m of space on both sides and at least 4ft/1.2m of space in front and WiFi signal is in good condition, and then turn on the power.

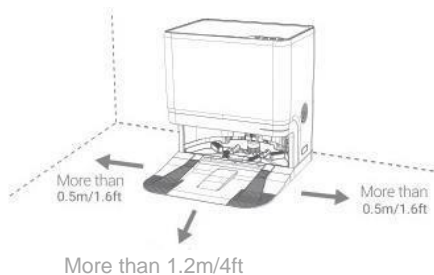

3. After placing the clean water tank, sewage tank and dust bag according to instruction, plug in the power cord. After the base station powered on, the white indicator light will be always on.

Note: Clean water is required in clear water tank.

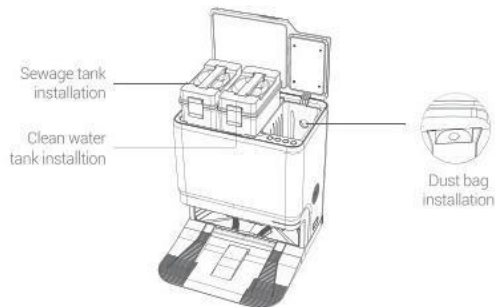

Quick Installation and Use

Instruction before use

(1) Before using it for the first time.

Please remove the bumper protectors and front impact protection film on the robot.



(2) Power on/off

Long pressing the home button to turn on the robot, the blue light breathes, the host enters the boot process. When the blue light is always on, then the boot is completed. When the host is in standby, press and hold the Home button to shut down. When the light is off, then the shutdown is completed

Note: The host cannot be turned off during charging.

Charging

Method 1: After long pressing the START button the machine is turned on, put the robot back into the base station for charging, and the robot will prompt "charging".

Method 2: Press the button on the robot or the button on the base station to activate the automatic recharging mode, and the robot will automatically return to the base station for charging.

Method 3: Click the recharge button on the APP to activate the automatic recharge mode, and the robot will automatically return to the base station for charging

Tips

- Please charge the robot when you use it for the first time. It takes about 5~6 hours to fully charge.
- In order to facilitate the return of the robot to the base station, it is recommended to let the robot start from the base station, and do not move the base station at will.
- Please place charging station in the same area, extra charging station will affect the recharge function of the robot.
- When the power of the robot is low and cannot be turned on, put the robot directly into the base station for charging.
- The robot is equipped with high-performance lithium battery. To maintain battery performance, keep the robot charged during dail

Quick Use Guide

Download the APP

- (1) Scan the QR code or search for "Smart life "in "APP Store" or 'google play' to download the APP



- (2) Press and hold the HOME  button and START button of the robot vacuum at the same time for 3 seconds to enter the network configuration mode, the button light flashes and there is a voice prompt.

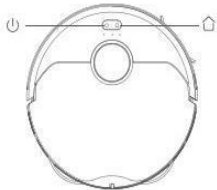

3) Enter the home page of APR add device according to the APP prompt.

Please refer to the following two distribution network methods

WiFi Distribution Network Mode

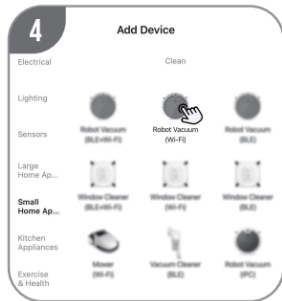
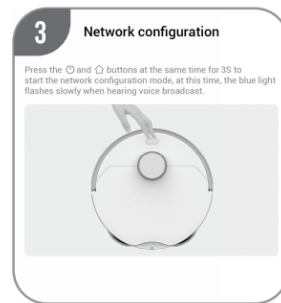

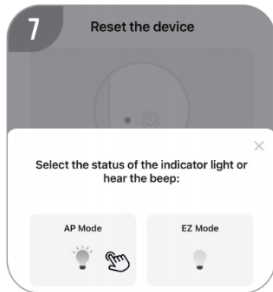

Bluetooth Distribution Network Mode

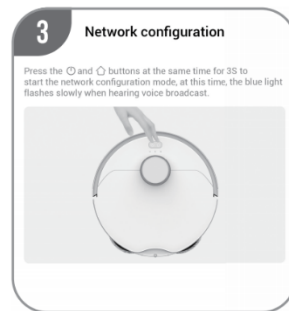

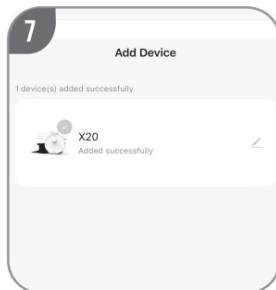
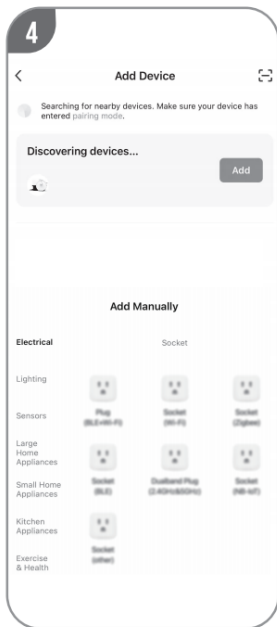

Quick Use Guide

Clean Mode

Press and hold the home button for a few seconds, the robot button light will turn on, and wait for the completion of the startup voice broadcast, then you can control the robot to work.

1. Auto Cleaning

- ① Press the start button on the robot vacuum to start the cleaning mode, and the robot starts to clean or,
- ② Press the button of the charging base lightly, and the robot starts to clean.
- ③ There are three cleaning modes available for the APP:

Sweeping mode:

When the robot enters sweeping mode, automatically returns to the base station to empty dust after cleaning

Mopping mode:

When the robot enters mopping mode, it will automatically return to the base station after mopping to clean the mops.

Sweeping and Mopping mode:

The robot enters sweeping and mopping mode, automatically returns to the base station to empty dust and then clean the mop.

Note: The robot will enter drying mode after each cleaning.

Tips;

- If the power is too low, the cleaning task cannot be performed, please charge it before starting the cleaning;
- If the power is too low during cleaning, the robot returns to the charging dock for recharge and resumes cleaning where it left off.

(2) Scheduled Cleaning

Set the scheduled cleaning time on APP. The robot will automatically start cleaning at the time you set and return to the charging base after cleaning.

Note:

-During the scheduled cleaning period, the host will not automatically renew the cleaning and play voice.

Smart Area

1. Area Cleaning

After Smart Map has been generated successfully, you can add an adjustable size and location cleaning area. The robot will only clean the selected area.

2. Designated Room Cleaning

After Smart Map has been generated successfully, you can divide the map into different areas according to the cleaning needs. You can set one or more cleaning areas. The robot will only clean the selected area.

3. No-go Zone

You can set the area that does not need to be cleaned as "No-go Zone" through the APP, and the robot vacuum will not enter the no-go zone.

Note

Please make sure the robot has generated the smart map. The No-go zone will be lost when the map is rebuilt.

The No-go zone may be lost due to changes in the location of the self-empty station or furniture. So please try not to move or interfere with the Robot while it is working.

Due to the continuous development and upgrade of APP, there may be slight adjustment of functions and details, please refer to the actual version.

4. Pause

When the robot is in the cleaning mode, press any key to pause the cleaning, press the Home key and the machine will continue to clean, press the key and the robot will return to the charging base and end the cleaning

5. Docking Mode

Auto mode: When the battery power is low, the robot will prompt "Low power, start docking mode", and returns to the charging station for recharge.

6. Manual mode:

In standby mode, press the back button on the host or the base station, or click the back button on the APP. After the voice prompt "Turn on the docking mode", the robot will automatically return to the base station to charge.

Quick Use Guide

Cleaning Mode

1. Troubleshooting

When an abnormality occurs during the operation of the robot, the indicator light flashes red quickly and there is a voice prompt. For the solution, please refer to 'Troubleshooting'

Note: It is in the fault state.

2. Power Off

If the robot is not used for longtime, please turn off the main power switch (It shuts down after 12 hours).



3. Reset Wi-Fi

When the router changed configuration, password forgot or mobile failed to connect with robot, press and hold and Start and Home button at the same time until the voice prompts, wait for the indicator light flashing blue and follow the APP prompts to reconfigure the network.

4. Do Not Disturb Mode

Using the APP you can manually turn on/off do not disturb mode or modify do not disturb period. In Do Not Disturb mode, the robot will not resume clean and play voice reminder.

5. Cleaning mode

Through the APP control, you can choose quiet standard and strong modes, and the default is the standard mode.

6. Dormant Sleep

No operation for more than 10 minutes, the host will automatically enter sleep state. In sleep state, the indicator light will be off and pressing any key can wake up the robot.

Quick Use Guide

Clean Mode

All-in-One Station

Cleaning the robot

- ① When the robot is in sweeping and mopping mode, to ensure the cleanliness of the mop, it will periodically return to the base station to clean the mop and replenish the water in the robot's water tank.
- ② After the cleaning task is over, the robot will automatically return to the base station for dust collection, mop cleaning, water injection and mop drying operations.

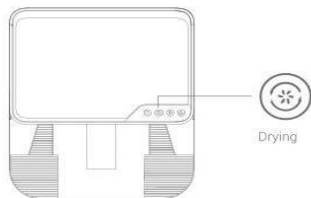

All-in-One Station self-cleaning

Tap the self-cleaning button on the base station to activate the self-cleaning function of the base station. When the base station is self-cleaning, please use the cleaning brush to assist the cleaning.

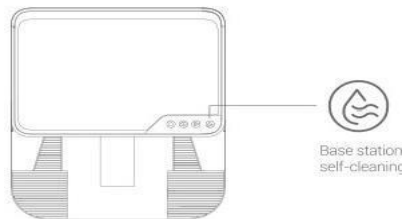

Maintenance

Accessories Cleaning and Maintenance

In order to maintain the normal operation of the robot vacuum, it's recommended to clean and maintain the robot vacuum regularly. Please turn off the power during maintenance.

Refer to the table below for the frequency of cleaning and maintenance of accessories:

Accessories	Cleaning Frequency	Replace Frequency
Mop	Automatic cleaning after returning to base station	Every 3-6 months
Side brush	Every 2 weeks	Every 3-6 months
Main brush	Every week	Every 3-6 months
High efficiency filter	Every week	Every 3-6 months
Dust bin	Every week	/
Base station sewage tank	Every week	/
Base station cleaning tank	Every week	/
Universal wheel	Every week	/
Driving wheel	Every week	/
Anti-fall sensor	Every week	/
Lidar	Every week	/

Maintenance Dust Bin

Take out the dust box, open the dust box cover, and empty the garbage.



Cleaning filters

(1) Take the filters out from the dust bin.



Maintenance

Clean the Primary Filter, High efficiency filter and Sponge with the Cleaning Tool provided.



If washed, please dry them before use.

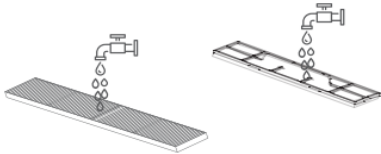

Put the High efficiency filter and Sponge back together in the dust bin.

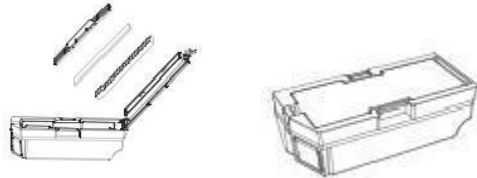

Cleaning Main Brush

Remove the roller brush cover and take out the roller brush. If there is a lot of dust in the suction port, please use a rag to clean. If there are hairs entangled in the brush, please use the upper blade of the cleaning tool to cut it off



Cleaning Side Brush

After removing the side brush, use the upper blade of the cleaning tool to clean the side brush and wipe with a cloth.

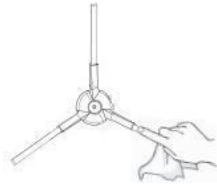

Maintenance

Cleaning Universal Wheel

Clean the universal wheel with a cloth.

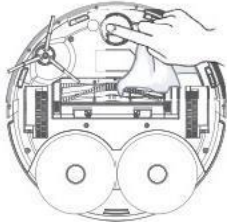

Cleaning Anti-fall sensor

Use a dry cloth to clean cliff sensors to ensure the sensitivity.

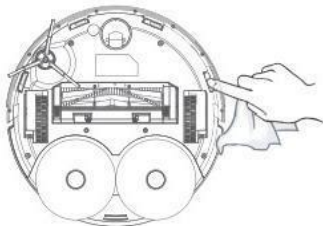

All -in-One Station self-cleaning

Clean the base station with a cleaning brush (recommended monthly cleaning)

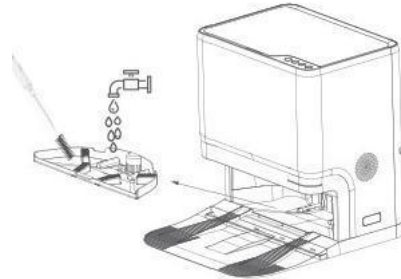

Firmware Upgrade

The robot firmware can be upgraded through the APP. When upgrading, please ensure that the robot is in charging state and has enough amount of power. The indicator light flashes when the firmware is in upgrading.

System Reset

If the system still cannot be used normally after resetting the system, please poke the reset hole under the flip cover in the power-on state to turn off the robot, then press and hold the button to restart the robot.

Product parameters

Packing List

Name	Quantity
Robot	1
Base station	1
Dust bag	2
Mop	4
Side brush	2
Filter	2

All in One Base Station

Name	Data
Dimensions	472*400*445
Rated power	1600W
Rated input	220V 50HZ
Rated output	24V/1.5A
Rated frequency	50W

Robot

Name	Data
Dimensions	350*350*95
Battery	5200mAh
Product weight	3.7Kg
Wireless connection	Wi-Fi Smart Quick Connect
Rated voltage	14.4V
Rated power	50W

1、 This product meets the requirements of "Administrative Measures for the Restriction of the Use of Hazardous Substances in Electrical and Electronic Products'

2、 In the term of environmental protection use, consumers in the normal process of use will not appear harmful substances leakage, precipitation and other problems affecting consumer health, can be assured to use.

3、 The environmental protection service life of our products is 10 years. The "environmental protection service life" is effective only when the products are used under normal conditions as described in this manual.

Component Name /Hazardous Substance	Lead	Mercury	Cadmium	hexavalent CT	Polybrominated biphenyls (PCBS)	Polybrominated diphenyl ethers
Plastic parts	0	0	0	0	0	0
Hardware	0	0	0	0	0	0
Sweeping electrical circuit module	0	0	0	0	0	0
Electronic components	0	0	0	0	0	0
Battery	0	0	0	0	0	0
Plug power cord metal part)	X	0	0	0	0	0

This table is prepared in accordance with SJ/T 11364

0: Indicates that the content of the hazardous substance in all homogeneous materials of the part is below the limit requirements specified in GB/T26572

X: Indicates that the amount of the hazardous substance in at least one homogeneous material of the part exceeds the limit requirements specified in GB/T26572

(Note: Some of the parts marked "X" above contain harmful substances exceeding the standard because of the current industry technical level, which cannot be replaced or reduced temporarily.)

Trouble shooting

	Problem	Reason	Solution
1	The sweeper won't charge	The base station not powered	Check if the indicator light of the dust collection station is on, if not, please re-plug
		Poor connection of charging contacts	Please use a dry cloth to wipe the charging poles of the base station and the sweeper
2	Sweeper is stuck	The sweeper is stuck on the loose objects on the ground	Before the sweeper starts to work, pick up clothing, scraps of paper, wires and fragile items on the floor to avoid getting stuck while working
		Sweeper stuck on furniture	The sweeper can pass through the bottom of furniture with a height of more than 11cm.If it is lower than this height, it may be stuck
3	The sweeper cannot return to the base station	The base station not powered	Check whether the indicator light of the base station is on. If not, remove and plug again
		The base station is not placed correctly	Remove the obstacles within 1.6ft/0.5m on the left and right side of the base station and within 4ft/1.2m in front of it. Please place the base station according to the instructions
		The cleaning is not started from the base station	Let the sweeper start cleaning from the base station
		The recharge path is blocked, for example the door of the room where the base station is placed is closed	Keep the recharge path clear

		The base station was moved.	Try to avoid moving the base station, let the sweeper complete the self-cleaning
		Wi-Fi does not have a signal	Reconnect ta Wi-Fi
4	The brush is abnormal	Side brush installation is not in place	Check if the side brush installed well
		brush may be stuck by entanglement	Check the brush for entanglement and clean the side brush
5	Weak suction	The dust bin is full	Empty the dust bin and replace with a new dust bag
		Filter is clogged or damp	Clean and dry the filter or replace with a new one
6	Failed to make a scheduled cleaning	The sweeper power is off	Ensure that the power switch of the sweeper is turned on and there is sufficient power to complete the cleaning
		Sweeper is in low power	Please charge
		The setting is not successful or has been cancelled on the APP	Please reschedule the cleaning according to the APP operation guide
7	Left/Right wheel abnormal	Left/right wheels may be stuck	Check left/right wheels for entanglement, and clean left and right wheels
8	Abnormal roller brush	The roller brush may be entangled	Check if the roller brush is tangled and jammed and clean the roller brush
9	Sweeper suspended in the air	The sweeper leaves the ground or gets stuck on the edge of a cliff	Please place the sweeper on the ground

Trouble shooting

	Problem	Reason	Solution
10	Laser radar anomaly	The sweeper leaves the ground or gets stuck on the edge of a cliff	Please place the sweeper on the ground
11	Infrared anti-collision bumper is abnormal	Infrared anti-collision bumper may be stuck	Tap the left, middle, and right side of the infrared anti-collision bumper to make it return to its place
12	The dust bin is abnormal	The dust bin may not be installed properly	Pull out the dust bin and reinstall it
13	The base station cannot be controlled	The communication between the host and the base station is abnormal	Place the host in front of the base station for control or press and hold the host recharge button and the base station recharge button for a few seconds until continuous beeping sounds, the host and the base station are successfully paired
14	Unable to configure APP	The sweeper is not within the network coverage of the router	Make sure the sweeper is within the network coverage of the router
		Sweeper cannot configure itself	Turn on the sweeper and reconfigure the network
		5G Wi-Fi networks are not supported	This model does not support 5G Wi-Fi network, please use 2.4G Wi-Fi network for configuration
15	Cleaning map lost	Moving sweeper to another floor, will cause the map to be lost	The sweeper will automatically re build the new sweep map
16	Unable to create smart map on APP	Moving the sweeper during cleaning causes it to be unable to locate	Try not to move the sweeper when it is working
		The automatic cleaning task has not been completed	When the sweeper finishes cleaning it automatically generates a map

17	The sweeper makes a strange sound when it is running	Side brush, rolling brush is entangled. The dust bin and filter are blocked	Cleaning and maintenance of the side brushes is recommended, and regular replacement of the roller brushes, dust box and filter accessories
		Sweeper enters strong power cleaning mode	Switch to standard cleaning mode
18	Pink light on station always on	The dust bag was removed or not installed properly	Re-insert the dust bag to ensure it has been installed properly
		Take out the clean water tank/no water	Check the water volume of the water tank, if the water volume is insufficient, please add water
		Take out the sewage tank/full of water	Check whether the water in the sewage tank is full. If full, pour out the sewage
		The cleaning tank is full	Start self-cleaning to drain the cleaning tank

Security Information

Information about rechargeable batteries

1.Lithium battery

Important: Lithium batteries and products containing lithium batteries are subject to strict transport regulations. If the product (including batteries)needs to be transported for long-term storage, travel, or any other reason, the following shipping instructions must be followed:

- Remove the battery from the sweeper.
- Apply a piece of insulating tape to the electrodes of the battery.
- Reinsert the battery with the tape and close the battery cover.
- When shipping, pack the product in its original packaging or suitable packaging.
- Can only be shipped by land and sea, not by air.

2.Storage battery

If the product needs to be stored for a long time, please remove the battery first.

Battery removal steps:

- ① Turn the machine over to the back.
 - ② Use a screwdriver or other suitable tool to remove the two battery cover screws.
 - ③ Take out the battery cover.
 - ④ Take out the battery.
- Store the product and battery in a cool, dry place.

3.Remove the battery

- Before disposing of the appliance, the battery must be removed from the appliance.
- The appliance must be switched off when removing the battery.
- Batteries should be disposed of safely.

Security Information

Use Restrictions

- This product is only used for floor cleaning in the home environment, do not use it outdoors (such as open balconies), non-floor (such as sofas), commercial or industrial environments
- Do not use it in a suspended environment (such as duplex floors, open balconies, furniture tops) without guardrails
- Do not use in environments above 40°C, below 0°C, or in environments with any liquid and sticky substances on the ground
- Please hang up the ground cables at home before use to avoid dragging the cables when the host is running
 - Please put away fragile items and sundries (such as vases, plastic bags, etc.) placed on the ground to avoid damage to valuables at home when the host is blocked or slightly collided during operation
- Do not allow persons with physical, mental or sensory disabilities, including children, to use or operate this product
- Do not let children use the robot as a toy. Please supervise children and pets to keep them away when the host is working
- Do not place the main brush cleaning tool in an area that can be touched by children
- Do not place any objects (including children, pets) on the stationary or moving main unit
- Do not let human or pet hair, fingers and other parts close to the vacuum port of the machine when the host is working
- Do not use to sweep any burning objects (such as unextinguished cigarette butts)
- Do not use for cleaning long-haired carpets (some dark-colored carpets may not be cleaned properly)
- Do not let the host pick up foreign objects or sharp objects (such as decoration waste, glass, iron nails, etc.)

- Do not use the protective cover of the laser ranging sensor, the upper cover of the main unit and the collision buffer as a handle to carry the machine
- Do not clean or maintain the main unit and the charging stand when the power is turned off or off
- Do not wipe any part of this product with a damp cloth or any liquid
- Please use this product in accordance with the instructions in the manual, any loss and injury caused by improper use shall be borne by the user

Warranty Card

User Name	
Full Address	
Phone Number	
Zip Code	
Product Model	
Purchase Date	
Serial Number	
Warranty Date	

Maintenance Record

	Maintenance Date	Description of The Fault and Parts Replacement	Maintenance Center	Maintenance Engineer
1				
2				
3				
4				

